

Features

- Bluetooth specification V.1.2 compliant
- Output power class 1 (20 dBm max)
- Transmission rate up to 721Kbps
- Working distance up to 100 meters
- ACL & SCO links
- AFH interference resistance
- Supports USB (1.1) /UART/PCM (Pulse Code Modulation) /SPI/I²C interfaces
- Optimized link manager and control
- Support wireless LAN coexistence in collocated scenario
- Integrated 4Mbit flash, 64Kbytes RAM, 4KBytes ROM
- 3.3V single supply voltage
- Hardware based UART flow control

Applications

- Serial cable replacement
- Industrial control
- POS terminals
- Data acquisition equipment
- Internet access points
- Machine control
- Sensor monitoring
- Robotic and bionic control
- Security control
- Patient monitoring
- Audio gateway applications
- Hands-free sets
- Wireless printers
- Cordless terminals
- Laptops, PCs and accessories
- Hand held devices and accessories
- HID devices (keyboard, mouse, joystick, game controller)

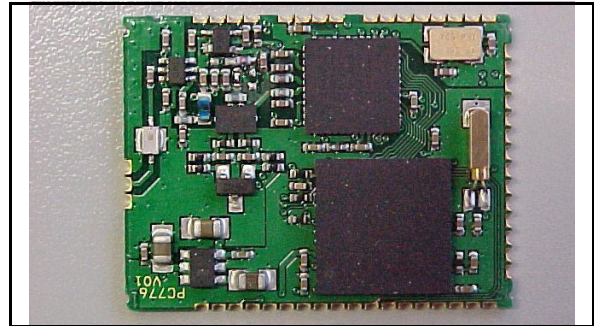

Order codes

- GS-BT2416C1

Description

ST Bluetooth Modules are highly integrated for easy implementation in embedded applications. Class 1 modules enable wireless communication with other Bluetooth enabled devices up to 100 m away. The GS-BT2416C1 integrates on a unique FR4 PCB support: BT 1.2 radio and baseband, memory, 32 KHz and 13 MHz oscillators, Vreg as well as PA function. The antenna has not been included in order to grant a degree of freedom to the user in selecting the most suitable design and placement between external and integrated antenna that could be SMA aerial or a low cost antenna trace designed on PCB. For more details please refer to GS-BT2416C1DB Application Note. Modules are coming without any SW to offer a further freedom degree to user that can embed his own solution or any available BT certified SW upon his choose and preference.

Certification

- CE Compliant IMQ Exp. Opinion 0081-AREF0017
 - Safety EN60950-1 (2001)
 - EMC EN301 489 17V1.2.1
 - Radio ES 300 328 V1.6
- BQB compliant

Contents

1	Maximum ratings	3
1.1	Absolute maximum ratings	3
1.2	Operating ranges	3
2	I/O specification	4
3	Bluetooth section	4
4	Block diagram	5
5	Pin settings	6
6	Mechanical dimensions	8
7	Revision history	10

1 Maximum ratings

1.1 Absolute maximum ratings

Operation of the module beyond these limits is not guaranteed.

Sustained exposure to these limits will adversely affect device reliability.

Table 1. Absolute maximum ratings

Symbol	Parameter	Values		Unit
		Min	Max	
V _{DD}	Module supply voltage		4	V
V _{IN}	Input voltage on any digital pin	V _{ss} -0.5	V _{dd} +0.3	V
T _{stg}	Storage temperature	-40	+85	°C
T _{sold}	Soldering temperature		240	

1.2 Operating ranges

Operating ranges define the limits for functional operation and parametrics characteristics of the module.

Functionality outside these limits is not implied

Table 2. Operating ranges

Symbol	Parameter	Conditions	Values			Unit
			Min	Typ	Max	
V _{DD}	Module supply voltage	-20°C < T < 70 °C	3.13	3.3	3.47	V
T _{stg}	Operating ambient temperature		-20		+70	°C

2 I/O specification

Table 3. DC Input / Output specification

Symbol	Parameter	Conditions	Values			Unit
			Min	Typ	Max	
V_{il}	Low level input voltage	$3.13\text{ V} < V_{DD} < 3.47\text{ V}$			0.8	V
V_{ih}	High level input voltage	$3.13\text{ V} < V_{DD} < 3.47\text{ V}$	2			V
V_{hyst}	Schmitt trigger hysteresis	$3.13\text{ V} < V_{DD} < 3.47\text{ V}$	0.4			V
V_{ol}	Low level output voltage	Io load = pin drive capability			0.15	V
V_{oh}	High level output voltage	Io load = pin drive capability	$V_{DD} - 0.15$			V

3 Bluetooth section

Table 4. Bluetooth section

Symbol	Parameter	Conditions	Values			Unit
			Min	Typ	Max	
P_{tr}	Transmission power	$3.13\text{V} < V_{DD} < 3.47\text{V}$		18	20	dBm
Sens	Sensitivity	$3.13\text{V} < V_{DD} < 3.47\text{V}$	-70			dBm
Flim	Frequency limit	$3.13\text{V} < V_{DD} < 3.47\text{V}$	2402		2480	MHz
CHs	channel space			1		MHz
Hop	Hopping			1600		hops/sec
RF ck	RF crystal oscillator			13		MHz
BB ck	Baseband crystal oscillator			32		kHz
Tra	Transmission rate asynchronous				721	kbits/sec
Trs	Transmission rate synchronous				432	kbits/sec
Iop	Operation current TX Mode			180		mA
	Operation current RX Mode			60		mA

4 Block diagram

Figure 1. Block diagram

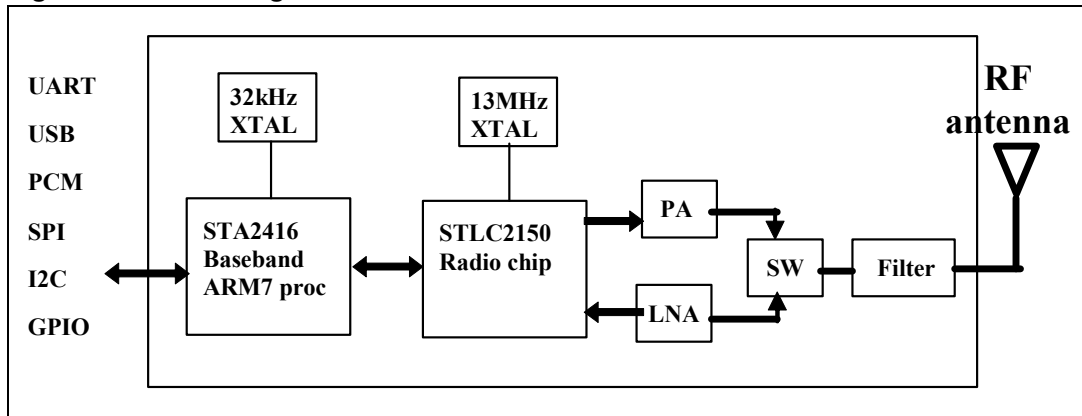

5 Pin settings

Table 5. Pin description

Pin N°	Name	I/O	Description
1	Vss1	--	GND
2	Vdd	--	Module supply voltage- Single 3.3V
3	GPIO0	I/O	General purpose I/O line
4	GPIO1	I/O	General purpose I/O line
5	GPIO2	I/O	General purpose I/O line
6	GPIO3	I/O	General purpose I/O line
7	GPIO4	I/O	General purpose I/O line
8	GPIO5	I/O	General purpose I/O line
9	----	I/O	Not to be used Internally used for RX/TX switch
10	GPIO7	I/O	General purpose I/O line
11	GPIO8	I/O	General purpose I/O line
12	GPIO9	I/O	General purpose I/O line
13	LP CLOCK OUT	---	32kHz Out
14	GPIO11	I/O	General purpose I/O line
15	----	I/O	Not to be used Internally used for TX gain setting
16	----	I/O	Not to be used Internally used for TX gain setting
17	----	I/O	Not to be used Internally used for TX gain setting
18	----	I/O	Not to be used Internally used for TX gain setting
19	TDI		JTAG pin
20	TDO		JTAG pin
21	TMS		JTAG pin
22	NTRST		JTAG pin
23	TCK		JTAG pin If not used connect to VSS1
24	I2C_dat	I/O	I2C bus interface data To be connected to VDD with 10 K Ω resistor
25	I2C_clk	I/O	I2C bus interface clock To be connected to VDD with 10 K Ω resistor

Table 5. Pin description (continued)

Pin N°	Name	I/O	Description
26	INT1	I	External Interrupt signal Internally connected to VSS1 with 10KΩ / If not used connect to VSS1
27	PCM_SYNC	I/O	PCM 8kHz synch
28	PCM_CLK	I/O	PCM clock
29	PCM_A	I/O	PCM Data In/Out
30	PCM_B	I/O	PCM Data In//Out
31	USB_DN	I/O	USB data - If not used connect to VSS1
32	USB_DP	I/O	USB data + If not used connect to VSS1
33	UART2_RXD	I	UART2 data input If not used connect to VDD
34	UART2_TXD	O	UART2 data output
35	UART2_I1	I	UART2 clear to send input If not used connect to VDD
36	UART2_O2	O	UART2 ready to send output
37	SPI_FRM	I/O	Synchronous Serial Interface frame synch
38	SPI_CLK	I/O	Synchronous Serial Interface clock
39	SPI_TXD	O/T	Synchronous Serial Interface transmit data
40	SPI_RXD	I	Synchronous Serial Interface receive data If not used connect to VSS1
41	1V8	O	1.8V digital supply out (test purpose) To be left Not Connected
42	3V3	O	3.3V I/O power supply out (test purpose) To be left Not Connected
43	Vss1	-	GND (test purpose) To be left Not Connected
44	2V7	O	2.7 digital core supply out (test purpose) To be left Not Connected
45	RESET	I	Reset pin (active low)
46	BOOT	I	External downloading Enable (active low) Internally pul-upped to 1.8V by 10kohm
47	UART10_TXD	O	UART1 data output
48	UART11_RXD	I	UART1 data input If not used connect to VDD
49	Vss2 (RF GND)	--	RF GND
50	+ANTENNA	--	Antenna out
51	Vss2 (RF GND)	--	RF GND

6 Mechanical dimensions

Figure 2. Mechanical dimensions

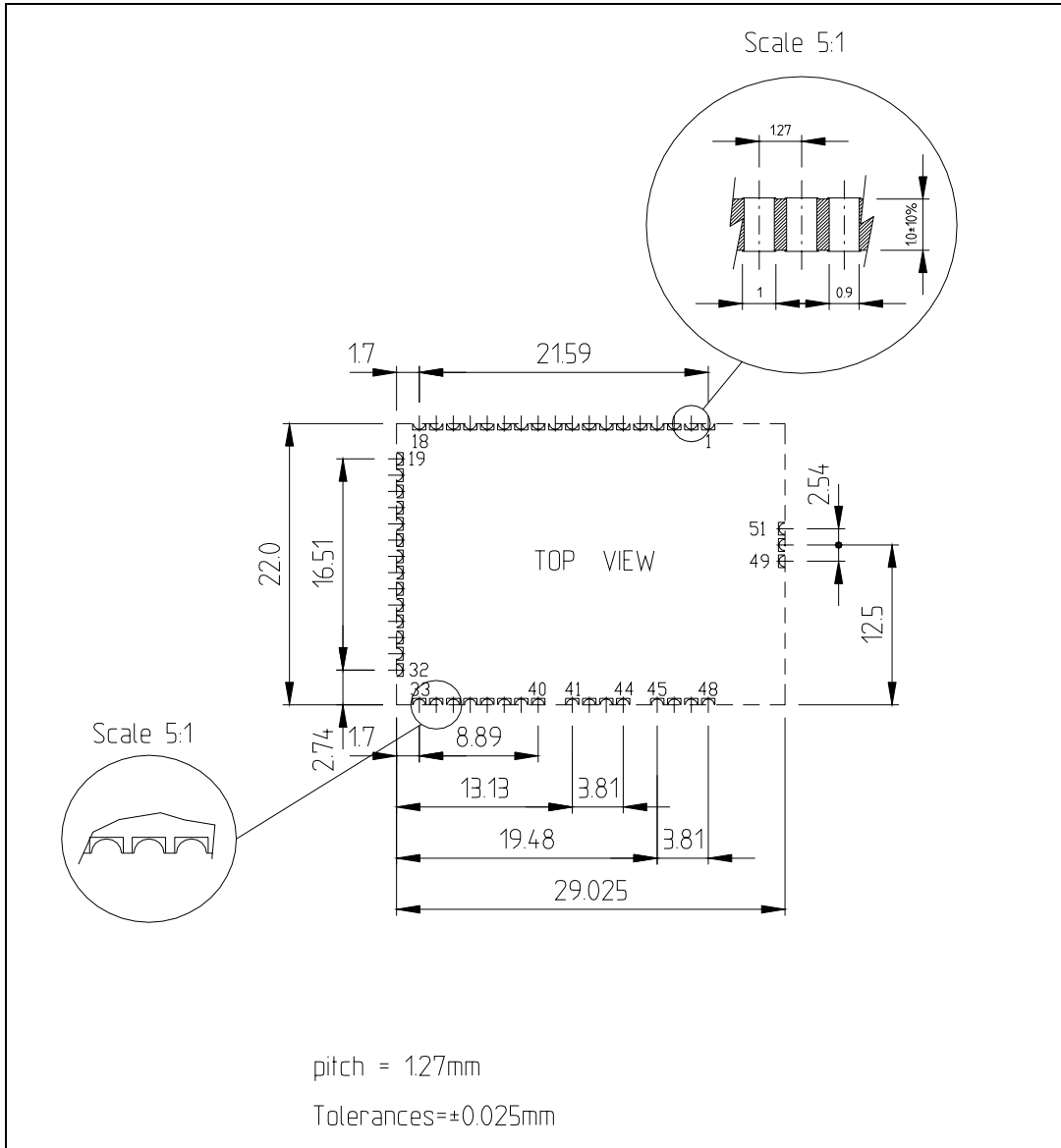
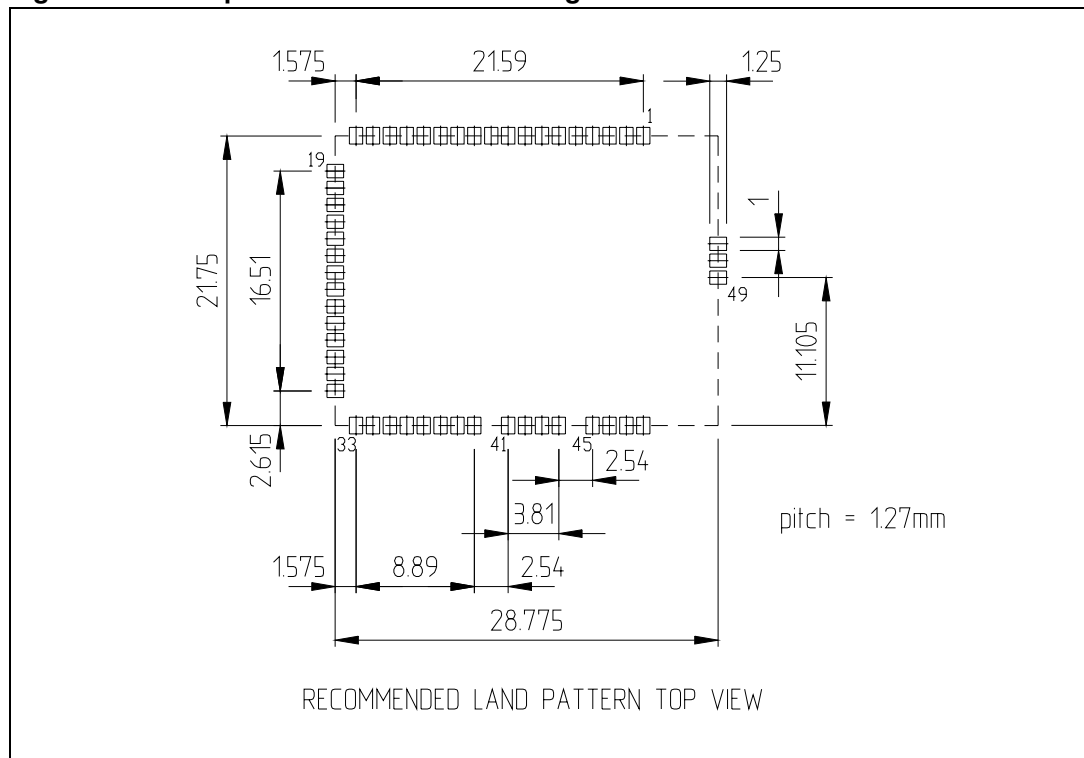

Figure 3. Land pattern and connection diagram



7 Revision history

Table 6. Revision history

Date	Revision	Changes
12-Dec-2006	1	First release
26-Jan-2007	2	Updated Table 4: Bluetooth section on page 4
30-Aug-2007	3	Updates involved: Cover page, Table 4 on page 4 , Table 5 on page 6 .

Please Read Carefully:

Information in this document is provided solely in connection with ST products. STMicroelectronics NV and its subsidiaries ("ST") reserve the right to make changes, corrections, modifications or improvements, to this document, and the products and services described herein at any time, without notice.

All ST products are sold pursuant to ST's terms and conditions of sale.

Purchasers are solely responsible for the choice, selection and use of the ST products and services described herein, and ST assumes no liability whatsoever relating to the choice, selection or use of the ST products and services described herein.

No license, express or implied, by estoppel or otherwise, to any intellectual property rights is granted under this document. If any part of this document refers to any third party products or services it shall not be deemed a license grant by ST for the use of such third party products or services, or any intellectual property contained therein or considered as a warranty covering the use in any manner whatsoever of such third party products or services or any intellectual property contained therein.

UNLESS OTHERWISE SET FORTH IN ST'S TERMS AND CONDITIONS OF SALE ST DISCLAIMS ANY EXPRESS OR IMPLIED WARRANTY WITH RESPECT TO THE USE AND/OR SALE OF ST PRODUCTS INCLUDING WITHOUT LIMITATION IMPLIED WARRANTIES OF MERCHANTABILITY, FITNESS FOR A PARTICULAR PURPOSE (AND THEIR EQUIVALENTS UNDER THE LAWS OF ANY JURISDICTION), OR INFRINGEMENT OF ANY PATENT, COPYRIGHT OR OTHER INTELLECTUAL PROPERTY RIGHT.

UNLESS EXPRESSLY APPROVED IN WRITING BY AN AUTHORIZED ST REPRESENTATIVE, ST PRODUCTS ARE NOT RECOMMENDED, AUTHORIZED OR WARRANTED FOR USE IN MILITARY, AIR CRAFT, SPACE, LIFE SAVING, OR LIFE SUSTAINING APPLICATIONS, NOR IN PRODUCTS OR SYSTEMS WHERE FAILURE OR MALFUNCTION MAY RESULT IN PERSONAL INJURY, DEATH, OR SEVERE PROPERTY OR ENVIRONMENTAL DAMAGE. ST PRODUCTS WHICH ARE NOT SPECIFIED AS "AUTOMOTIVE GRADE" MAY ONLY BE USED IN AUTOMOTIVE APPLICATIONS AT USER'S OWN RISK.

Resale of ST products with provisions different from the statements and/or technical features set forth in this document shall immediately void any warranty granted by ST for the ST product or service described herein and shall not create or extend in any manner whatsoever, any liability of ST.

ST and the ST logo are trademarks or registered trademarks of ST in various countries.

Information in this document supersedes and replaces all information previously supplied.

The ST logo is a registered trademark of STMicroelectronics. All other names are the property of their respective owners.

© 2007 STMicroelectronics - All rights reserved

STMicroelectronics group of companies

Australia - Belgium - Brazil - Canada - China - Czech Republic - Finland - France - Germany - Hong Kong - India - Israel - Italy - Japan - Malaysia - Malta - Morocco - Singapore - Spain - Sweden - Switzerland - United Kingdom - United States of America

www.st.com